

# Technical Data

For areas which experience frost or snow and perhaps have less than reliable water quality, the Edwards LX Series 2 system is the only choice. It uses the highly efficient heat transferring properties of a special anti-freeze fluid to transfer the absorbed energy to heat the water indirectly.

With an 'indirect system' water does not pass through the collector panels, instead the antifreeze mixture is circulated from the collectors through a jacket which is wrapped around the storage tank, transferring the heat into the water.

The benefit of this 'indirect' heat exchange process is that the system can be used confidently in frost areas, without risking damage to the system; it offers protection against freeze damage in conditions of up to minus 8 degrees Celsius.

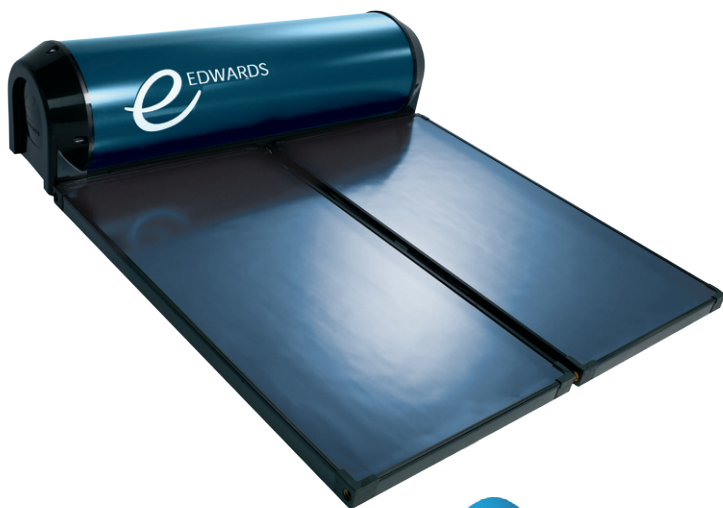

The storage cylinders for all Edwards roof-mounted solar water heaters are constructed from long life 1.6mm Marine Grade 316 stainless steel. Stainless steel acts as a natural barrier to corrosion. Therefore, Edwards stainless steel systems do not require a sacrificial anode and are virtually maintenance free. On the other hand, competitors mild steel cylinders with vitreous glass lining are prone to corrosion once the anode has been mostly consumed.

The new modern design of the LX Series 2 system was designed and manufactured in Australia for a range of conditions. Not only will it complement any home's roof and save you immediately on your home's energy costs, it offers you peace of mind knowing it has been developed to last for years.

### FEATURES INCLUDE:

- A range of systems to suit your needs
- Long life stainless steel cylinder
- Choice of electric or in-line gas boosting
- Choice of contemporary colours
- Australian designed and manufactured
- Collector glass designed specifically for solar application

### BENEFITS INCLUDE:

- Hot water available in all weather conditions
- Energy consumption reduced for water heating by 50% - 85%\*
- Reduction in fossil fuel consumption assists in reducing CO<sup>2</sup> production
- Peace of mind Edwards warranty
- Award winning design

## SPECIFICATIONS

	Units	LX180	LX305	LX440
<b>Storage Cylinder</b>				
Capacity	litres	180	305	440
Outside Dimensions	mm	571 x 1215	571 x 1905	571 x 2700
Heating Circuit Capacity (approx.)	litres	5	9	12
Weight - Full	kg	241	393	564
Weight - Empty	kg	61	88	124
Working Pressure	kPa	850	850	850
Insulation - (Polyurethane) Thickness	mm	47	47	47

<b>Solar Collectors</b>				
Number of	-	1	2	3
Capacity	litres	Refer to specific collector data sheet		
Dimensions	mm	1941 x 1027 x 84	1941 x 2094 x 84	1941 x 3181 x 84
Nominal Surface Area	m <sup>2</sup>	2	4	6
Weight - Full	kg	Refer to specific collector data sheet		
Weight - Empty	kg	Refer to specific collector data sheet		

<b>Total System</b>				
Dimensions - Area on roof	mm	2562 x 1615	2562 x 2494	2562 x 3581
Weight - Full*	kg	281	472	681
Weight - Empty*	kg	94	154	223

\* Total system weight based on use of Australis series 2 collectors

<b>Water Supply</b>				
TPR valve setting	kPa	850	psi	125
ECV* setting	kPa	700	psi	100
Max. supply pressure with ECV	kPa	550	psi	80
Max. supply pressure without ECV	kPa	680	psi	100
Min. supply pressure	kPa	200	psi	29

<b>Electric Boost Specifications</b>				
Heating unit type		Copper sheath immersion element		
Supply voltage		220 V - 250 V		
Hourly recovery rate @ temperature rise of:				
Rating	Current	40°C	50°C	60°C
kW	Amps	litres/hr	litres/hr	litres/hr
2.4	10	52	41	34
3.6	15	77	62	52

### Installation - with

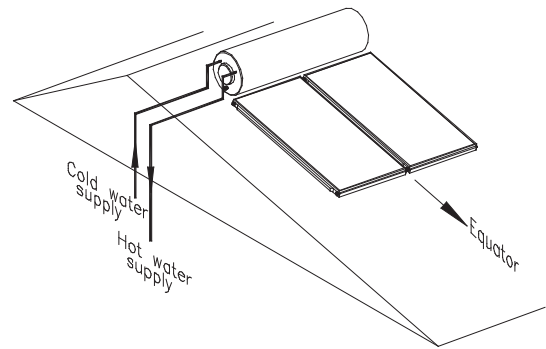

### Installation - against

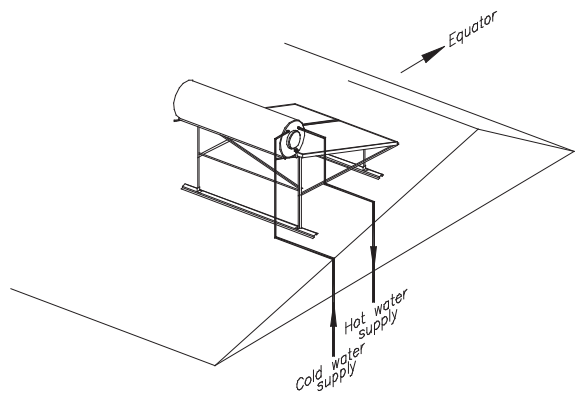

### Installation - side

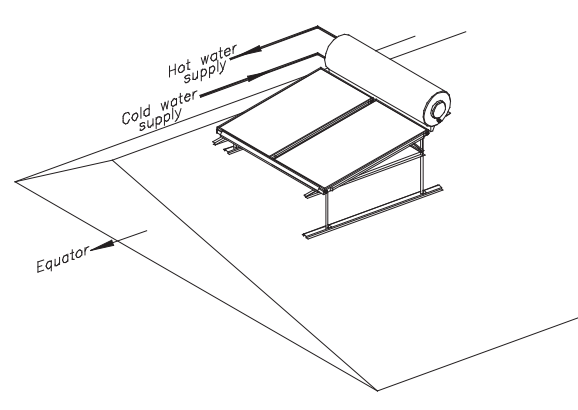

\* Savings of 50%-85% shown are based on Australian Government approved TRNSYS simulation modelling. Savings and incentives will vary depending upon your location, type of Edwards system installed, orientation and inclination of the solar collectors, type of water heater being replaced, hot water consumption and fuel tariff. Maximum financial savings off your hot water bill are achievable when replacing an electric water heater on continuous tariff.

Your local distributor:



**EDWARDS**  
solar hot water®

For sales assistance call  
**132 949 (Australia Only)**

For International Enquires

Tel +61 8 9351 4600

Fax +61 8 9351 8034

Website [www.edwards.com.au](http://www.edwards.com.au)

Email [info@edwards.com.au](mailto:info@edwards.com.au)

ABN 21 098 823 511