

Technical Data

If your home is in a temperate or tropical location, which is not subject to frost, and you have good quality drinking water, then the L Series 2 system is ideal. This system operates on the natural thermosiphon principle, i.e. when water is heated it rises. The L Series 2 system directly heats the water as it passes through the collectors and then automatically circulates it back into the storage tank. This process continues whilst the sun is shining, giving you and your family hot water free from the sun.

The storage cylinders for all Edwards roof-mounted solar water heaters are constructed from long life 1.6mm Marine Grade 316 stainless steel. Stainless steel acts as a natural barrier to corrosion. Therefore, Edwards stainless steel systems do not require a sacrificial anode and are virtually maintenance free. On the other hand, competitors mild steel cylinders with vitreous glass lining are prone to corrosion once the anode has been mostly consumed.

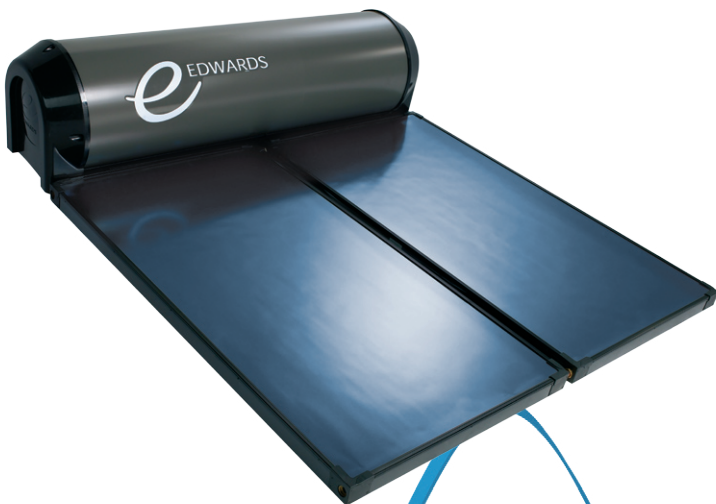

The outer casing of Edwards roof mounted solar water heaters is constructed from highly durable, weatherproof COLORBOND® steel. Edwards offer a choice of seven (7) modern COLORBOND® steel colours with their roof mounted range. This colour choice allows you to choose a system which will complement your roof and blend with your home's aesthetics. All this at no additional cost!

The new modern design of the L Series 2 systems will add value to any home. This, combined with the strength of long lasting stainless steel and the confidence of purchasing a quality Australian designed and manufactured product, will provide you with peace of mind when enjoying your new Edwards L Series 2 Solar Hot Water System.

FEATURES INCLUDE:

- A range of systems to suit your needs
- Long life stainless steel cylinder
- Choice of electric or in-line gas boosting
- Choice of contemporary colours
- Australian designed and manufactured
- Collector glass designed specifically for solar application

BENEFITS INCLUDE:

- Hot water available in all weather conditions
- Energy consumption reduced for water heating by 50% - 90%*
- Reduction in fossil fuel consumption assists in reducing CO₂ production
- Peace of mind Edwards warranty
- Award winning design.

SPECIFICATIONS

	Units	L180	L305	L440
Storage Cylinder				
Capacity	litres	180	305	440
Outside dimensions	mm	571 x 1215	571 x 1905	571 x 2700
Weight - full	kg	232	384	555
Weight - empty	kg	52	79	115
Working pressure	kPa	850	850	850
Insulation - (Polyurethane) thickness	mm	47	47	47
Solar Collectors				
Number of	-	1	2	3
Capacity	litres	Refer to specific collector data sheet		
Dimensions	mm	1941 x 1027 x 84	1941 x 2094 x 84	1941 x 3181 x 84
Nominal surface area	m ²	2	4	6
Weight - full	kg	Refer to specific collector data sheet		
Weight - empty	kg	Refer to specific collector data sheet		
Total System				
Dimensions - area on roof	mm	2562 x 1615	2562 x 2494	2562 x 3581
Weight - full*	kg	267	454	660
Weight - empty*	kg	85	145	214

* Total system weight based on use of Australis series 2 collectors

Water Supply				
TPR valve setting	kPa	850	psi	125
ECV* setting	kPa	700	psi	100
Max. supply pressure with ECV	kPa	550	psi	80
Max. supply pressure without ECV	kPa	680	psi	100
Min. supply pressure	kPa	200	psi	29

Electric Boost Specifications				
Heating unit type		Copper sheath immersion element		
Supply voltage		220 V - 250 V		
Hourly recovery rate @ temperature rise of:				
Rating	Current	40°C	50°C	60°C
kW	Amps	litres/hr	litres/hr	litres/hr
2.4	10	52	41	34
3.6	15	77	62	52

Your local distributor:

Installation - with

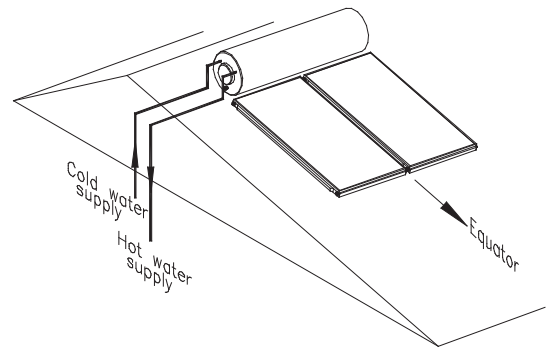

Installation - against

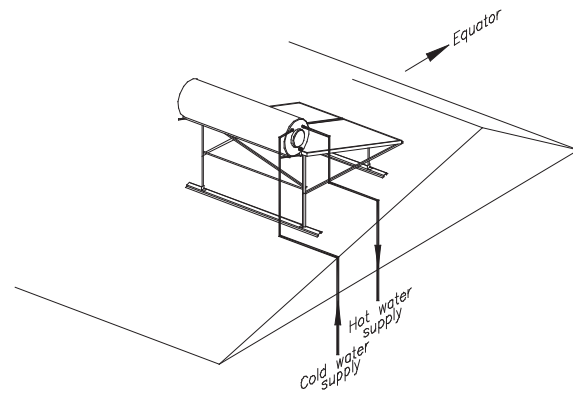

Installation - side

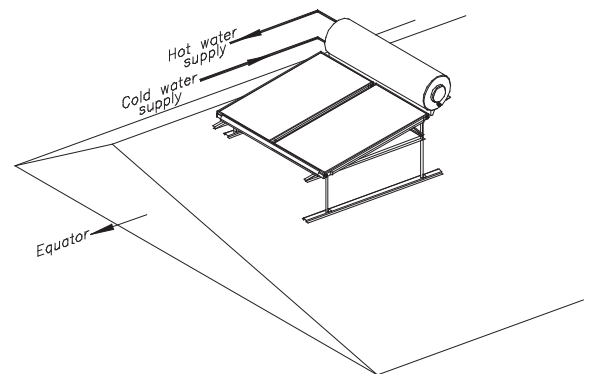

* Savings of 50%-90% shown are based on Australian Government approved TRNSYS simulation modelling. Savings and incentives will vary depending upon your location, type of Edwards system installed, orientation and inclination of the solar collectors, type of water heater being replaced, hot water consumption and fuel tariff. Maximum financial savings off your hot water bill are achievable when replacing an electric water heater on continuous tariff.



EDWARDS
solar hot water®

For sales assistance call
132 949 (Australia Only)

For International Enquires

Tel +61 8 9351 4600

Fax +61 8 9351 8034

Website www.edwards.com.au

Email info@edwards.com.au

ABN 21 098 823 511